



LSC25

LSC30

**Landoll Stand Up Ride
Compact Electric Lift Truck**

STANDARD FEATURES

- 2 or 3-Stage High Visibility Mast
- 2,500 lb. (1,136 kg) or 3,000 lb. (1,361 kg) Capacity
- Multi-Function Control for Lift/Lower, Direction and Speed Control
- Single 24 Volt AC Traction and DC Pump Controller
- Tiller Controlled Hydraulic Power Steering
- Cantilevered Overhead Guard
- Thick Cushioned Rubber Floor Mat
- Horn, Battery Discharge Indicator and Hour Meter
- Left Foot Operated Electric Deadman Parking Brake
- Right Foot Operated Hydraulic Front Wheel Service Brakes
- 10" x 5" (250mm x 127mm) Smooth Poly Rear Drive/Steer Tire
- 14" x 5" (356mm x 127mm) Smooth Poly Front Load Tires
- Easily Removable Covers for Access to all Major Components
- Easily Replaceable Hydraulic Filter Element
- Battery Compartment can be Set Up for Left or Right Removal
- Battery Compartment Slide Strips for Easy Side Removal
- 36" (914mm) High Load Backrest and 34" (864mm) Wide Fork Carriage
- 42" (1067mm) Tapered Forks

- 3 Spool Hydraulic Control Valve
- Meets ANSI B56.1 Requirements

OPTIONAL FEATURES

- LED Headlights with Dash Switch
- LED Low Profile Strobe (Increases Overhead Guard Height 1" (25mm))
- Bolt-on Third Forward Overhead Guard Post
- Removable Swing-Out Rear Door
- Rear Operator's Compartment Floor Extension
- Backup Alarm, Beeping
- 36" (914mm), 40" (1,000mm) or 48" (1,200mm) Forks
- Integral Sideshifter with 8" (203mm) Stroke
- Integral Side Shifting Fork Positioner
- Freezer Conditioning for -22° F (-30° C)
- Rear Locking Safety Belt Restraint
- Fire Extinguisher
- 48" (1,200mm) High Load Backrest

LANDOLL CORPORATION

www.landoll.com/mhp | 800-428-5655



<https://forklift-manuals.jimdofree.com>

TECHNICAL DATA

MODEL			LSC25	LSC30
Capacity		at 24" (600mm) Load Center	lbs/kg 2,500 / 1,136	3,000 / 1,361
Truck Weight		with Battery	lbs/kg 6,950 / 3,152	6,800 / 3,084
Travel Speed		Loaded	mph/kph 6 / 9.7	6 / 9.7
		Unloaded	mph/kph 7 / 11.3	7 / 11.3
Lift Speed		Loaded	fpm/mpm 35 / 11	35 / 11
		Unloaded	fpm/mpm 62 / 19	62 / 19
Lowering Speed		Loaded	fpm/mpm 90 / 27.4	90 / 27.4
		Unloaded	fpm/mpm 80 / 24.3	80 / 24.3
Mast Tilt		Back / Fwd - Simplex Mast	degrees 8 / 5	8 / 5
		Back / Fwd - Triplex Mast	degrees 5 / 5	5 / 5
Lost Load Center	E		in/cm 10.7 / 27	10.7 / 27
Wheelbase	F	Mast Vertical	in/cm 36.1 / 92	42.1 / 107
Rear Overhang	G		in/cm 16.9 / 43	16.9 / 43
Overall Length to Fork Face	H	Mast Vertical	in/cm 63.7 / 162	69.7 / 177
Underclearance	I		in/cm 3 / 7.7	3 / 7.7
Operator Floor Height	J		in/cm 10.5 / 27	10.5 / 27
Overhead Guard Height	K		in/cm 87 / 221	87 / 221
Overall Width	L		in/cm 37 / 94	37 / 94
Fork Carriage Width	M		in/cm 34 / 86	34 / 86
Fork Length	N		in/cm 42 / 107	42 / 107
Out to Out Fork Spread	O	Minimum/Maximum	in/cm 9.4-32.5 / 24-83	9.4-32.5 / 24-83
Outside Turning Radius	P		in/cm 54 / 137	60 / 152
Right Angle Stacking Aisle	Q	with 48" L x 40" W (1200mm x 1000mm) Load	in/cm 118 / 300	124 / 315
Battery Compartment Height	R	Floor to Top of Slider Bars	in/cm 15.5 / 39	15.5 / 39
Equal Intersecting Aisle	S	Mast Vertical with 36" (914mm) Forks	in/cm 61 / 155	65 / 165
Gradeability		Loaded / Unloaded	% 7 / 12	7 / 12
Hydraulic Motor Rating		Continuous Duty Rating	type/kwh DC/3	DC/3
Traction Motor Rating		Continuous Duty Rating	type/kwh AC / 4.7 KWH	AC / 4.7 KWH
Traction Control Type		Induction	AC	AC
Hydraulic Control Type		Series	DC	DC
Wheel Sizes		Front 2 Each Poly-Dia x face	in/cm 14x5 / 36x13	14x5 / 36x13
		Rear 1 Each Poly-Dia x face	in/cm 12x5 / 30x13	12x5 / 30x13

LSC25 LSC30

Landoll Stand Up Ride Compact Electric Lift Truck



Low Step Height Operator Rear Entry

MAST DIMENSIONS

Max. Fork Height (A)		Lowered Height (B)		Free Lift Height (C)		** Max. Overall Height (D)	
Inches	Meters	Inches	Meters	Inches	Meters	Inches	Meters
Simplex (2 Stage) Mast (Minimum Free Lift)							
81	2.06	60	1.52	5.5	0.14	117	2.97
130	3.30	85	2.16	5	0.13	166	4.22
Triplex (3 Stage) Mast (*Maximum Free Lift)							
170	4.32	77	1.96	41	1.04	206	5.23
198	5.03	87	2.21	51	1.30	234	5.94
216	5.49	95	2.41	59	1.50	252	6.40

* Free Lift Based on 36" (914mm) High Load Backrest
 ** Max Overall Height Based on 36" (914mm) Load Backrest
 Dimensions Based on 3" (76.2mm) Mast Underclearance

RECOMMENDED BATTERIES

Battery Compartment Inside Clear Dimensions: 36.5"x13.6"x31" (92.7cm x 34.5cm x 78.7 cm)						
Battery	Amp Hour	X Dim in/cm	Y Dim in/cm	Z Dim in/cm	Wt. lbs/kg	Cover
12-125-15	875	35.44/90	13/33	31/79	1561/709	Yes
12-125-13	750	30.94/79	13/33	31/79	1365/620	Yes
12-100-13	600	30.94/79	13/33	26.25/67	1118/508	Yes

Leads are Required at Position B, 20" (51 cm) Long, SB350 AMP Red Connector

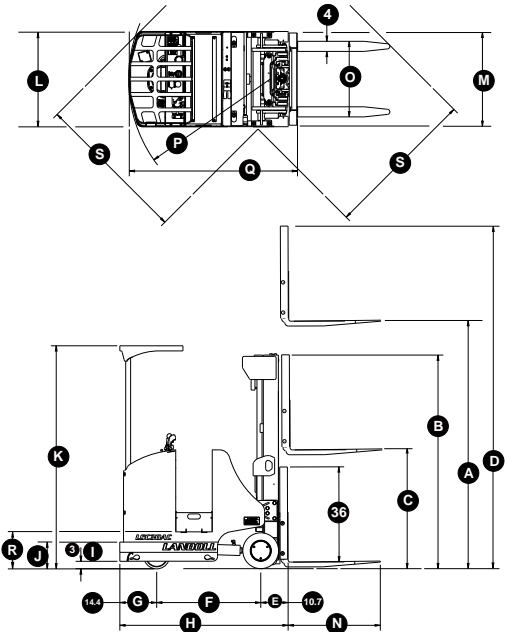

The specifications contained in this spec sheet are subject to change at any time without notice. Actual dimensions and performance data given herein may vary due to manufacturing tolerances.



www.landoll.com/mhp

1900 North Street | Marysville, KS 66508 | (800) 428-5655



Intertek



Member Company



<https://forklift-manuals.jimdofree.com>

B40-50AC-DR-0717