



HNF-150

Diesel Forklift Truck



福建名牌



GB/T19001



00111Q211047R0M/3500

***THE BEST INVESTMENT AT THE BEST PRICES
FOR THE BEST PERFORMANCE***

HNF-150

Diesel Forklift Truck

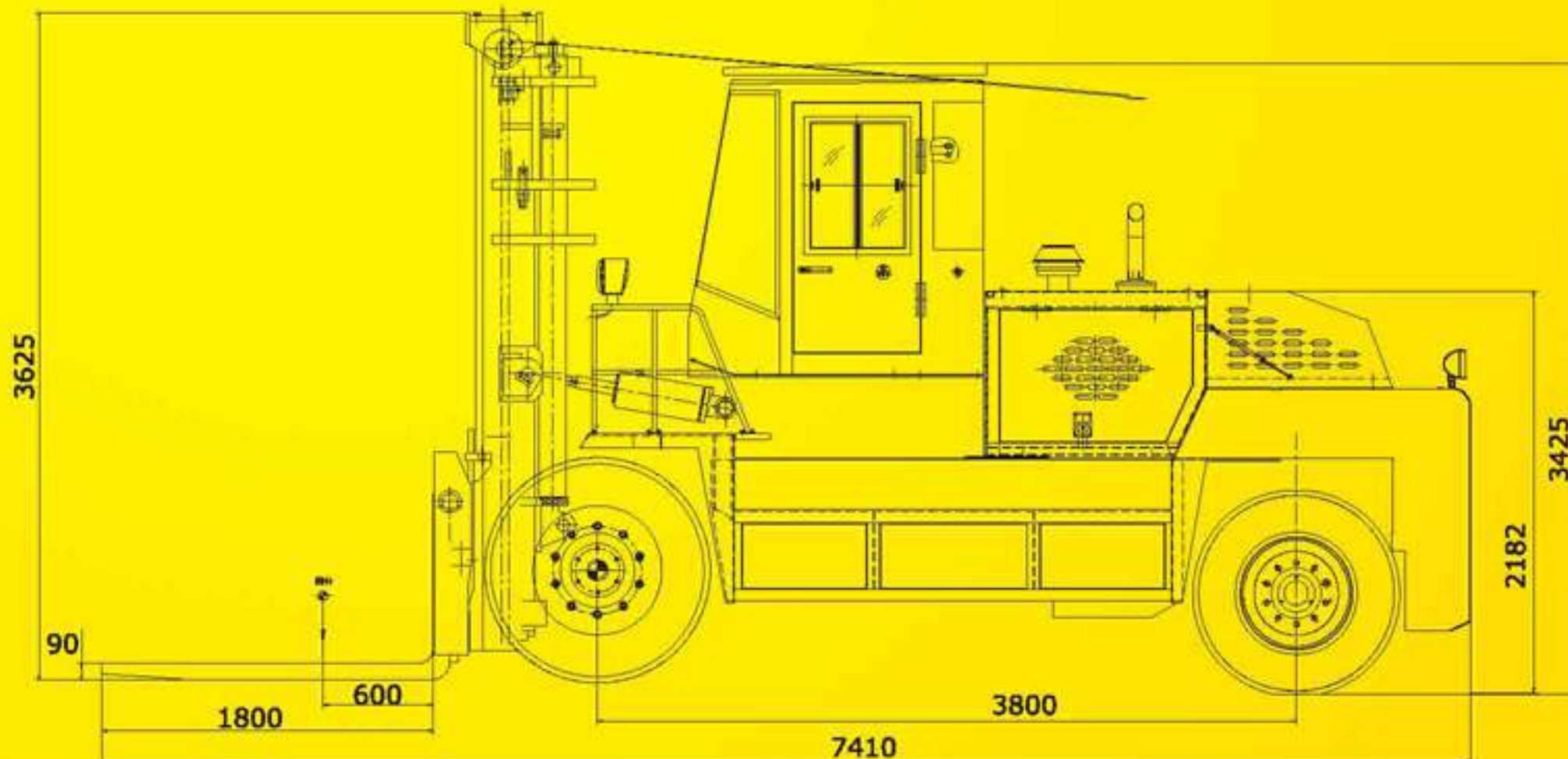

Main Technical Characteristics:

Engine: Dongfeng Cummins Engine 6BTAA5.9-C190, low oil consumption, high quality turbocharged engine, good power performance, big torque reserves, has strong power, energy conservation and environmental protection

Steering axle: adopt transverse oil cylinder type steering bridge, full-hydraulic steering, flexible and light, reliable

Transmission & torque converter: imported technology, reliable performance, convenient maintenance, smooth transmission, and convenient operation

Control system: pilot valve control device to make the work efficiency and reduce drivers* labor intensity

Hydraulic system: double pump confluence, small system flow, low power consumption, reliable performance, excellent operating performance

Pipeline: high pressure oil line use the first brand Parker Oil Tube, impact resistance, wear resistance and long service life

Tyre: sino-us joint brand, resistant to wear and sting, high strength tyres, bear heavy loaded - safe and reliable

Fork: use Cascade Fork, higher strength, more wearproof, highly increase the service life

Mast: box-type internal-external mast, special all-round roller bearings, increase lifting performance

Cab: with cooling and heating air-conditioning, and rupture membrane, explosion proof, heat insulation, prevent glare, sound insulation. Damping luxury cab with sunroof, wide view and comfortable seats, flexible control.

Parameters of the Diesel Forklift Truck HNF-150

Item	Unit	HNF-150
Rated load-lifting capacity	kg	15000
Weight	kg	20000
Max. lifting height	mm	3500
Load center distance	mm	600
Max. lifting speed	mm/s	300
Mast tilt angle (Front/Rear)	deg.	6/12
Travel speed		
Max. travel speed	km/h	30
Min. turning radius	mm	5800
Min. ground clearance	mm	250
Gradeability	%	20
Total length	mm	7410
Total width	mm	2750
Total height	mm	3625
Fork size	mm	1800*180*90
Wheelbase	mm	3800
Front wheel tread	mm	2060
Rear wheel tread	mm	2330
Engine		
Rated power	kw	142
Rated revolution speed	rpm	2200
Oil pressure of hydraulic system	Mpa	16
Tyre specifications		
Front		4x12.00-24-18PR
Rear		2x12.00-20-18PR

Note: the above data are subject to change without prior notice.



HNF-160

Diesel Forklift Truck



福建名牌



GB/T19001



00111Q211047R0M/3500

THE BEST INVESTMENT AT THE BEST PRICES
FOR THE BEST PERFORMANCE

HNF-160

Diesel Forklift Truck

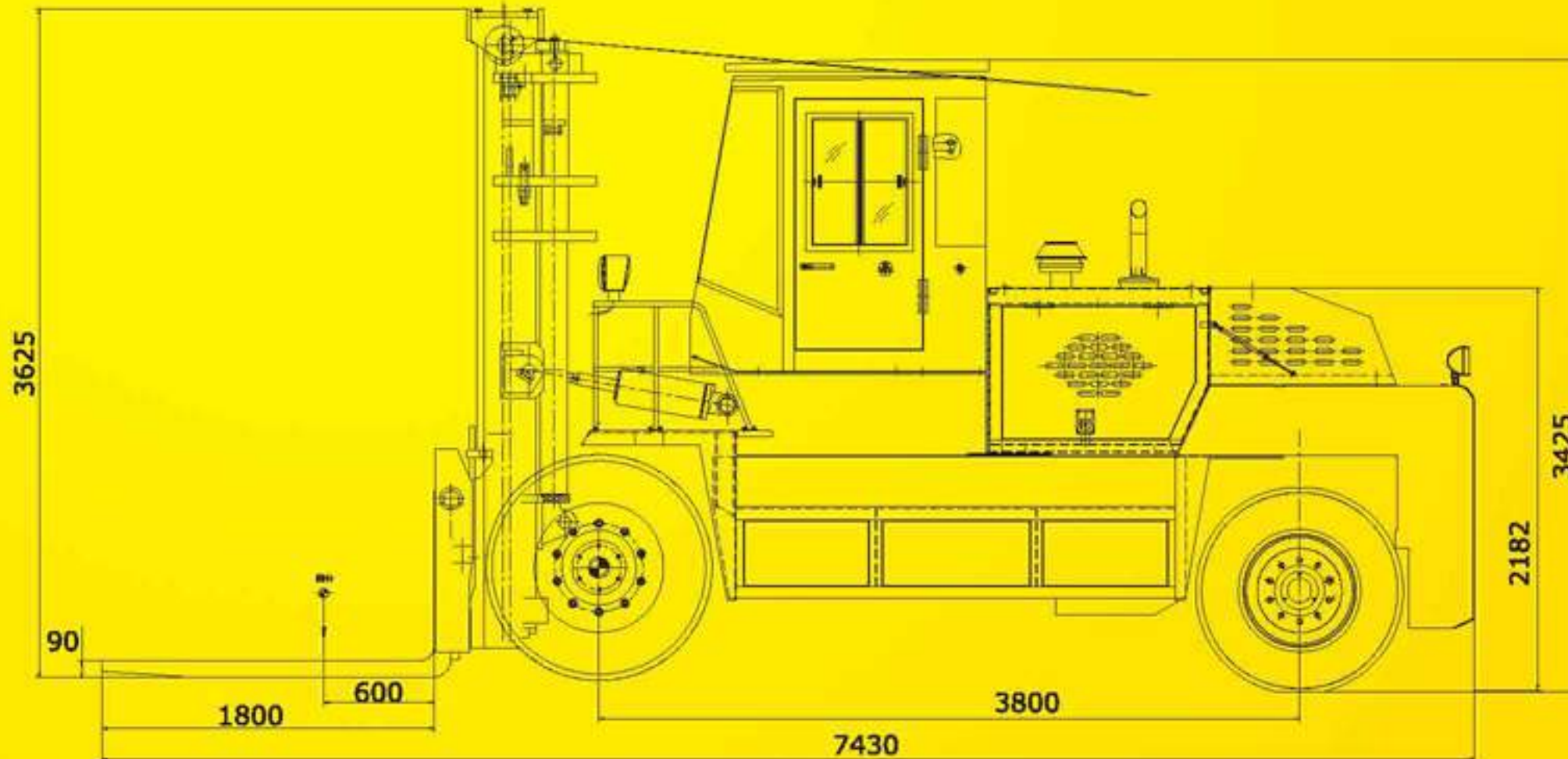

Main Technical Characteristics:

Engine: Dongfeng Cummins Engine 6BTAA5.9-C190, low oil consumption, high quality turbocharged engine, good power performance, big torque reserves, has strong power, energy conservation and environmental protection

Steering axle: adopt transverse oil cylinder type steering bridge, full-hydraulic steering, flexible and light, reliable

Transmission & torque converter: imported technology, reliable performance, convenient maintenance, smooth transmission, and convenient operation

Control system: pilot valve control device to make the work efficiency and reduce drivers' labor intensity

Hydraulic system: double pump confluence, small system flow, low power consumption, reliable performance, excellent operating performance

Pipeline: high pressure oil line use the first brand Parker Oil Tube, impact resistance, wear resistance and long service life

Tyre: sino-us joint brand, resistant to wear and sting, high strength tyres, bear heavy loaded - safe and reliable

Fork: use Cascade Fork, higher strength, more wearproof, highly increase the service life

Mast: box-type internal-external mast, special all-round roller bearings, increase lifting performance

Cab: with cooling and heating air-conditioning, and rupture membrane, explosion proof, heat insulation, prevent glare, sound insulation. Damping luxury cab with sunroof, wide view and comfortable seats, flexible control.

Parameters of the Diesel Forklift Truck HNF-160

Item	Unit	HNF-160
Rated load-lifting capacity	kg	16000
Weight	kg	20000
Max. lifting height	mm	3500
Load center distance	mm	600
Max. lifting speed	mm/s	300
Mast tilt angle (Front/Rear)	deg.	6/12
Travel speed		
Max. travel speed	km/h	30
Min. turning radius	mm	5800
Min. ground clearance	mm	250
Gradeability	%	20
Total length	mm	7430
Total width	mm	2750
Total height	mm	3625
Fork size	mm	1800*180*90
Wheelbase	mm	3800
Front wheel tread	mm	2060
Rear wheel tread	mm	2330
Engine		
Rated power	kw	142
Rated revolution speed	rpm	2200
Oil pressure of hydraulic system	Mpa	16
Tyre specifications		
Front		4x12.00-24-18PR
Rear		2x12.00-20-18PR

Note: the above data are subject to change without prior notice.



HNF-200

Diesel Forklift Truck



福建名牌



GB/T19001



00111Q211047R0M/3500

***THE BEST INVESTMENT AT THE BEST PRICES
FOR THE BEST PERFORMANCE***

HNF-200

Diesel Forklift Truck

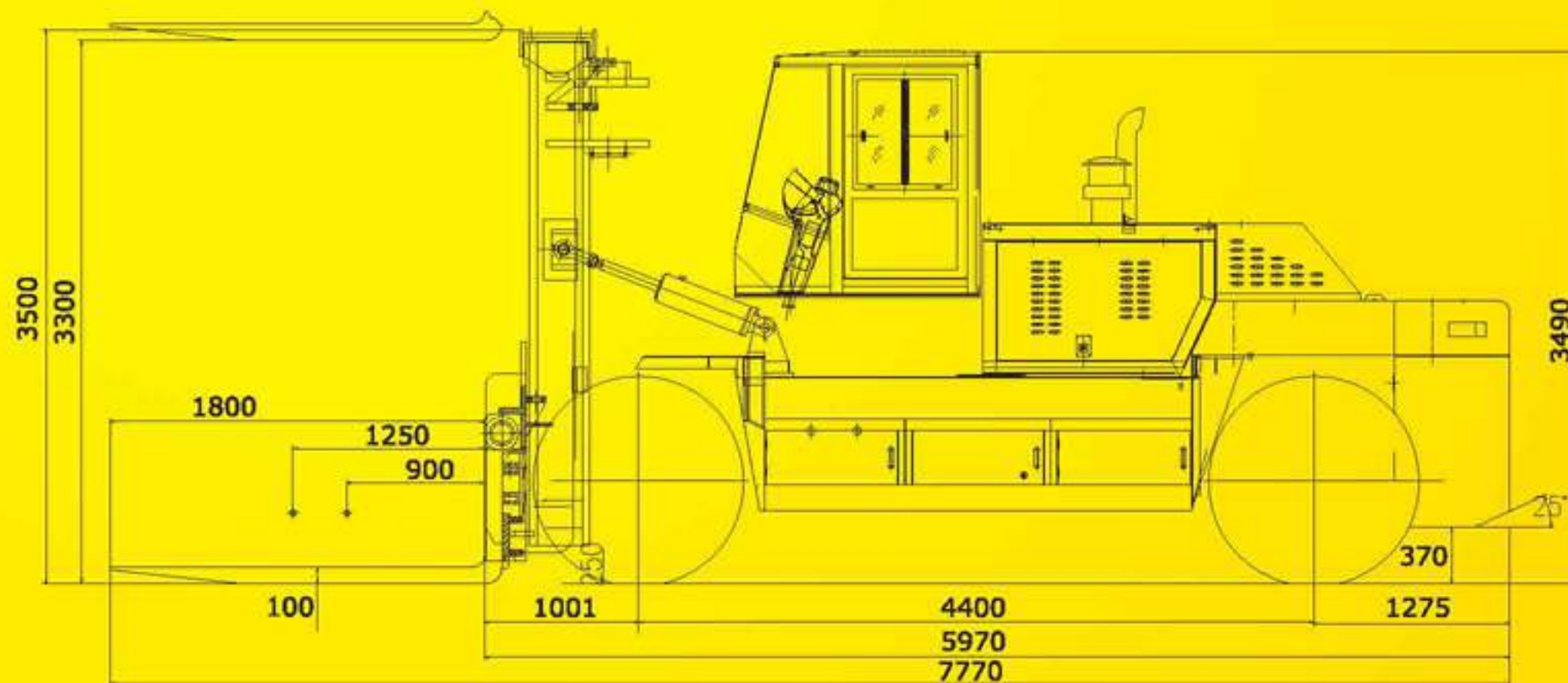

Main Technical Characteristics:

Engine: Dongfeng Cummins Engine 6CTA8.3-C215, low oil consumption, high quality turbocharged engine, good power performance, big torque reserves, has strong power, energy conservation and environmental protection

Steering axle: adopt transverse oil cylinder type steering bridge, full-hydraulic steering, flexible and light, reliable

Transmission & torque converter: imported technology, reliable performance, convenient maintenance, smooth transmission, and convenient operation

Control system: pilot valve control device to make the work efficiency and reduce drivers' labor intensity

Hydraulic system: double pump confluence, small system flow, low power consumption, reliable performance, excellent operating performance

Pipeline: high pressure oil line use the first brand Parker Oil Tube, impact resistance, wear resistance and long service life

Tyre: sino-us joint brand, resistant to wear and sting, high strength tyres, bear heavy loaded - safe and reliable

Fork: use Cascade Fork, higher strength, more wearproof, highly increase the service life

Mast: box-type internal-external mast, special all-round roller bearings, increase lifting performance

Cab: with air-conditioning and heating, and rupture membrane, explosion proof, heat insulation, prevent glare, sound insulation. Damping luxury cab with sunroof, wide view and comfortable seats, flexible control.

Parameters of the Diesel Forklift Truck HNF-200

Item	Unit	HNF-200
Rated load-lifting capacity	kg	20000
Weight	kg	26000
Max. lifting height	mm	3300
Load center distance	mm	900
Max. lifting speed	mm/s	180
Mast tilt angle (Front/Rear)	deg.	6/12
Travel speed		
Max. travel speed	km/h	25
Min. turning radius	mm	5800
Min. Groundclearance	mm	230
Gradeability	%	20
Total length	mm	7770
Total width	mm	3020
Total height	mm	3500
Fork size	mm	1800*260*100
Wheelbase	mm	4000
Front wheel tread	mm	2200
Rear wheel tread	mm	2390
Engine	model	Dongfeng Cummins 6CTA8.3-C215
Rated power	kw	160
Rated revolution speed	rpm	2200
Oil pressure of hydraulic system	Mpa	16
Tyre specifications		
Front		4x14.00-24-24PR
Rear		2x14.00-24-24PR

Note: the above data are subject to change without prior notice.



HNF-250

Diesel Forklift Truck



福建名牌



GB/T19001



00111Q211047R0M/3500

***THE BEST INVESTMENT AT THE BEST PRICES
FOR THE BEST PERFORMANCE***

HNF-250

Diesel Forklift Truck

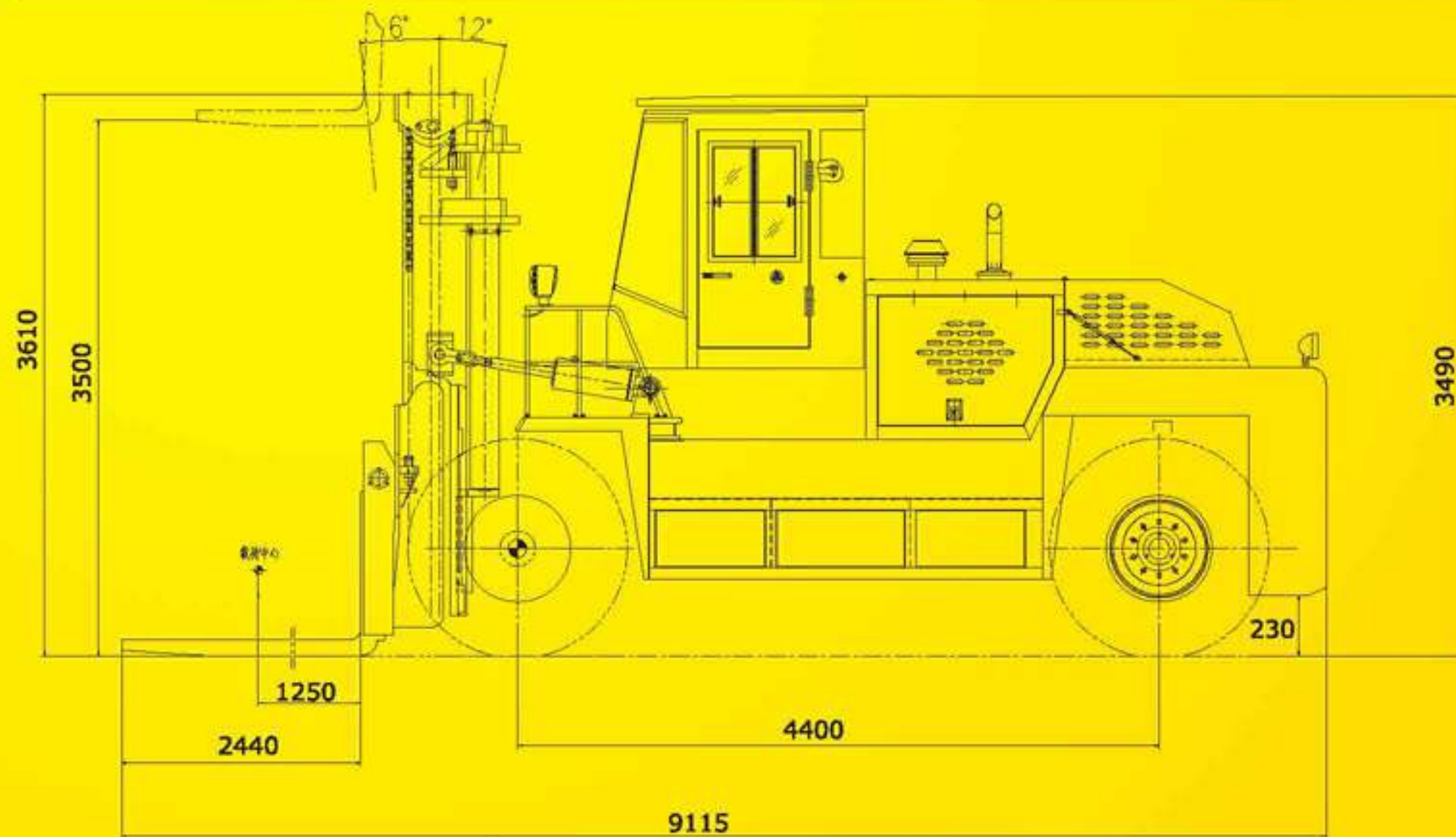

Main Technical Characteristics:

Engine: Dongfeng Cummins Engine 6CTA8.3-C240, low oil consumption, high quality turbocharged engine, good power performance, big torque reserves, has strong power, energy conservation and environmental protection

Steering axle: adopt transverse oil cylinder type steering bridge, full-hydraulic steering, flexible and light, reliable

Transmission & torque converter: imported technology, reliable performance, convenient maintenance, smooth transmission, and convenient operation

Control system: pilot valve control device to make the work efficiency and reduce drivers' labor intensity

Hydraulic system: double pump confluence, small system flow, low power consumption, reliable performance, excellent operating performance

Pipeline: high pressure oil line use the first brand Parker Oil Tube, impact resistance, wear resistance and long service life

Tyre: sino-us joint brand, resistant to wear and sting, high strength tyres, bear heavy loaded - safe and reliable

Fork: use Cascade Fork, higher strength, more wearproof, highly increase the service life

Mast: box-type internal-external mast, special all-round roller bearings, increase lifting performance

Cab: with air-conditioning and heating, and rupture membrane, explosion proof, heat insulation, prevent glare, sound insulation. Damping luxury cab with sunroof, wide view and comfortable seats, flexible control.

Parameters of the Diesel Forklift Truck HNF-250

Item	Unit	HNF250
Rated load-lifting capacity	kg	25000
Weight	kg	32000
Max. lifting height	mm	3500
Load center distance	mm	1250
Max. lifting speed	mm/s	180
Mast tilt angle (Front/Rear)	deg.	6/12
Travel speed		
Max. travel speed	km/h	28
Min. turning radius	mm	6500
Min. ground clearance	mm	230
Gradeability	%	20
Total length	mm	9115
Total width	mm	3020
Total height	mm	3610
Fork size(L*W*H)	mm	2440x280x110
Wheelbase	mm	4400
Front wheel tread	mm	2200
Rear wheel tread	mm	2390
Engine		
Rated power	kw	179
Rated revolution speed	rpm	2200
Oil pressure of hydraulic system	mpa	18
Tyre specifications		
Front		4x14.00-24-28PR
Rear		2x14.00-24-28PR

Note: the above data are subject to change without prior notice.



HNF-300

Diesel Forklift Truck



福建名牌



GB/T19001



00111Q211047R0M/3500

***THE BEST INVESTMENT AT THE BEST PRICES
FOR THE BEST PERFORMANCE***

HNF-300

Diesel Forklift Truck

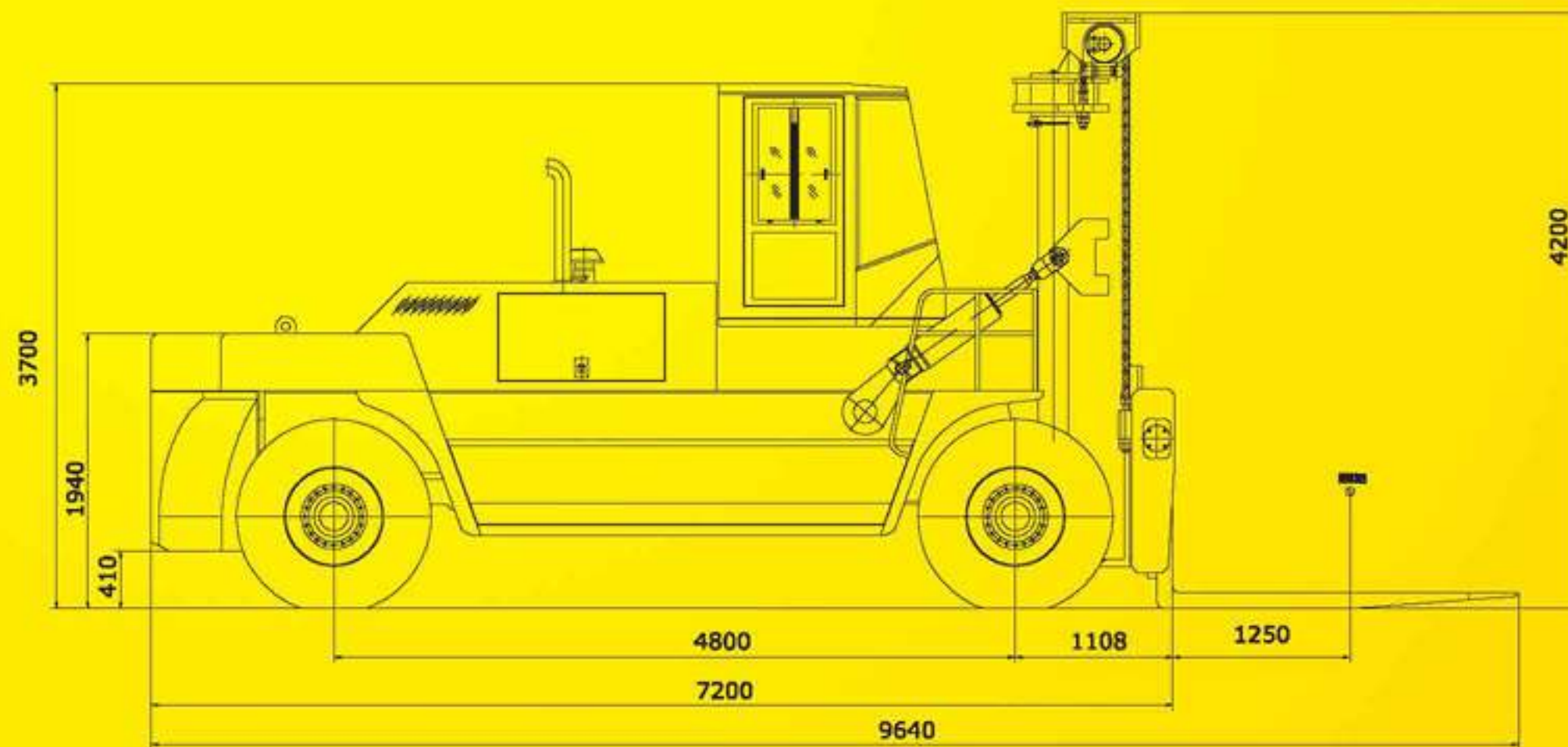

Main Technical Characteristics

Engine: Dongfeng Cummins Engine 6CTA8.3-C260, low oil consumption, high quality turbocharged engine, good power performance, big torque reserves, has strong power, energy conservation and environmental protection

Steering axle: adopt transverse oil cylinder type steering bridge, full-hydraulic steering, flexible and light, reliable

Transmission & torque converter: imported technology, reliable performance, convenient maintenance, smooth transmission, and convenient operation

The fully closed type keeps water, dust, impurities outside. Stable performance and high security

Control system: pilot valve control device to make the work efficiency and reduce drivers' labor intensity

Hydraulic system: double pump confluence, small system flow, low power consumption, reliable performance, excellent operating performance

Pipeline: high pressure oil line use the first brand Parker Oil Tube, impact resistance, wear resistance and long service life

Tyre: sino-us joint brand, resistant to wear and sting, high strength tyres, bear heavy loaded - safe and reliable

Fork: use Cascade Fork, higher strength, more wearproof, highly increase the service life

Mast: box-type internal-external mast, special all-round roller bearings, increase lifting performance

Cab: with air-conditioning and heating, and rupture membrane, explosion proof, heat insulation, prevent glare, sound insulation. Damping luxury cab with sunroof, wide view and comfortable seats, flexible control.

Parameters of the Diesel Forklift Truck HNF-300

Item	Unit	HNF-300
Rated load-carrying capacity	kg	30000
Weight	kg	38000
Max. lifting height	mm	3000
Load center distance	mm	1250
Max. lifting speed	mm/s	260
Mast tilt angle (front/rear)	Deg.	6/12
Max. travel speed	km/h	28
Min. turning radius	mm	6800
Min. ground clearance	mm	300
Gadeability	%	20
Total length (with fork)	mm	9640
Total width	mm	3200
Total height (Mast/cab)	mm	4200/3700
Fork size	mm	2440x320x110
Wheelbase	mm	4800
Front wheel	mm	2490
Rear wheel	mm	2450
Engine		
Rated power	kw	191
Rated rotation speed	Rpm	2200
Oil pressure of hydraulic system	Mpa	18
Tyre specifications		
Front		4x14.00-24-28PR
Rear		2x14.00-24-28PR

Note: the above data are subject to change without prior notice.